



CAST IRON / DUCTILE IRON SWING CHECK VALVE TO BSEN12334 WITH COUNTER-WEIGHT

Model 3941



PRESSURE RATING:

PN16 / PN25

TESTING PRESSURE:

PN X 1.5 on body.

PN X 1.1 on seat.

CONNECTION:

Flange to BS EN1092-2 (BS4504)

PN16/PN25

COATING:

Fusion bonded epoxy coated internally and externally.

MATERIALS:

Body, Cover and Disc

Cast Iron to BSEN1561 EN-GJL-250.; Alt.

Ductile Iron BSEN1563

Hinge Pin

Stainless Steel BSEN10088 1.4301; Alt.

Stainless Steel BSEN10088-1 1.4401

Body Seat Ring and Disc Seat Rings

Gunmetal to BSEN1982 CC491K;

Alt. Stainless Steel BSEN10088-1 1.4401

Hinge Stud Gasket, Cover Gasket

EPDM

Lever & Weight

Cast Iron to BSEN1561 EN-GJL-250

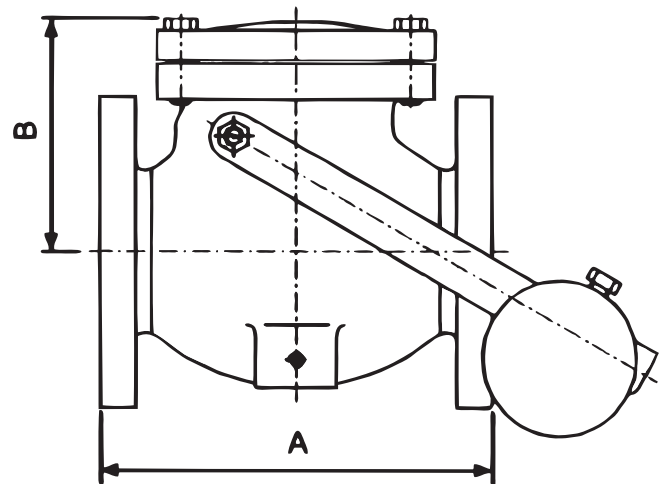

DIMENSIONS:

SIZE	A	B	Flange to BSEN1092-2 PN16 (BS4504 PN16)				
			D	C	n	Øh	t
50	203	121	165	125	4	18	20
65	216	135	185	145	4	18	20
80	241	141	200	160	8	18	22
100	292	168	220	180	8	18	24
125	330	182	250	210	8	18	26
150	356	215	285	240	8	22	26
200	495	267	340	295	12	22	30
250	622	305	405	355	12	26	32
300	698	343	460	410	12	26	32
350	787	450	533	470	16	26	36
400	914	520	597	525	16	30	38
450	965	550	640	585	20	30	40
500	1067	590	715	650	20	33	42
600	1219	680	840	770	20	36	48

* All dimensions in mm.

* Larger sizes are available on request.

RIGHT IS RESERVED FOR DEVELOPMENT AND IMPROVEMENT IN DESIGN, MATERIALS, AND MANUFACTURING PROCESS.

PIPEMATE INTERNATIONAL LTD.